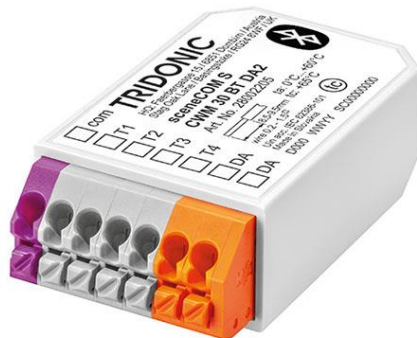

**sceneCOM S CWM 30 BT DA2**

sceneCOM S (single-channel)

**Product description**

- \_ DALI-2 Application Controller
- \_ Support for complete Tridonic control gear with DALI and DALI-2, as well as control gear certified by other manufacturers with DALI and DALI-2
- \_ Future-proof thanks to simple firmware update via Bluetooth App (sCS commissioning)
- \_ 4 independent inputs enabling connection of floating contact, standard momentary switches
- \_ Power supply via DALI line
- \_ Small dimensions
- \_ 5 years guarantee (conditions at [www.tridonic.com](http://www.tridonic.com))

**Interfaces**

- \_ DALI line
- \_ 4 independent inputs enabling connection of floating contact, standard momentary switches
- \_ Wireless communications via Bluetooth

**Functions**

- \_ DALI addressing
- \_ DALI Grouping
- \_ Sensor-based automation including presence/movement detection, daylight-linking
- \_ Tunable white application
- \_ Mobile commissioning APP (sCS commissioning) with the intuitive user interface available for Android and iOS

**Website**

<http://www.tridonic.com/28002205>



**sceneCOM S CWM 30 BT DA2**  
sceneCOM S (single-channel)

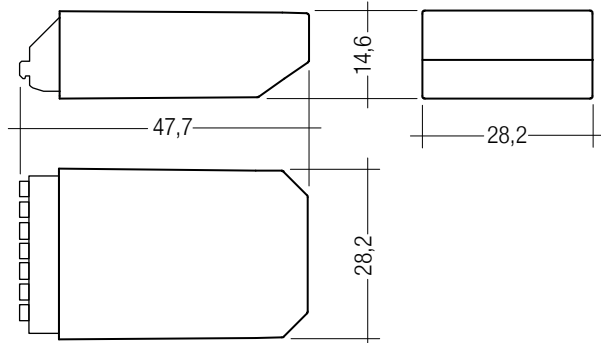

**Ordering data**

Type	Article number	Packaging, carton	Weight per pc.
sceneCOM S CWM 30 BT DA2	28002205	60 pc(s).	0.012 kg

**Technical data**

Supply via	DALI cable
Supply voltage <sup>①</sup>	9.5 – 22.5 V
Current draw	max. 30 mA
Bluetooth version	≥ 4.1
Bluetooth range	up to 20 m
Input	4 momentary-action switches or relays
Output	DALI
Ambient temperature $t_a$	0 ... +60 °C
$t_c$ point	65 °C
Storage temperature $t_s$	-25 ... +60 °C
Humidity	20 ... 90 % not condensed
Starting time	≤ 6 s
Type of protection	IP20
Mounting	Mounting box 60 x 61 (ø x d)
Housing material	Lexan 923
Housing colour	Light grey, similar to RAL 7035
Dimensions L x W x H	47.7 x 28.2 x 14.6 mm

**Approval marks**



**Standards**

EN 61347-2-11, EN 61347-1, EN 300 328, EN 301 489-1 V2.1.1, EN 301 489-17, EN 55015, EN 61547, EN 62479, EN 62386-101 (DALI-2), EN 62386-103, EN 62386-301, EN 62386-332

<sup>①</sup> U<sub>in</sub> acc. IEC 62386-101.

## 1. Standards

- EN 61347-2-11:2001
- EN 61347-1:2015
- EN 300 328 V2.1.1
- EN 301 489-1 V2.1.1
- EN 301 489-17 V3.1.1
- EN 55015:2013 + A1:2015
- EN 61547:2009
- EN 62479:2010
- EN 62386-101 Ed.2
- EN 62386-103 Ed.1
- EN 62386-301
- EN 62386-332

## 2. Installation

- Device can be inserted into the mounting box for the momentary switch.
- Device must not be connected to the mains. It is supplied directly via the DALI signal line.
- The momentary switches are connected directly to the device (potential free contacts) and must not be connected to the mains.
- DALI signals are not SELV. Therefore the same procedures should be applied as working with mains voltage.
- Only one momentary switch for each device output.
- Only one application controller in the same DALI network allowed.
- Maximum range of the signal is up to 20 m. Avoid mount the device behind glass, concrete surfaces or in metal enclosures. If mounted behind such materials the signal range will be reduced.

### 2.1 Connection diagrams

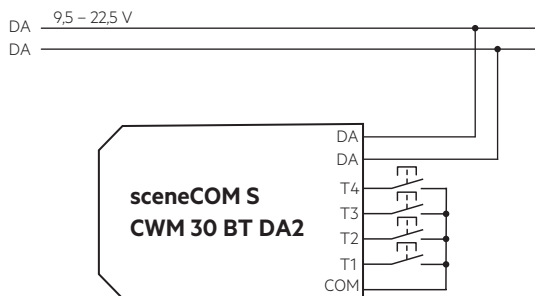
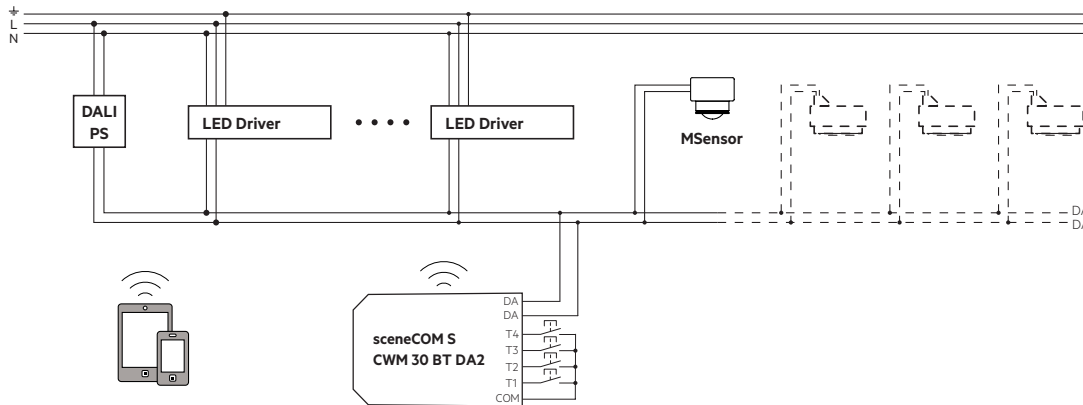

### 1.1 DALI note



Device is developed as Multi-Master Application Controller according to DALI Standard EN 62386-101 Ed.2, also known as DALI-2. Device should not be used in combination with other application controllers.

### 1.2 Glow wire test

according to EN 61347-2-11 passed for temperatures up to 850°C.

### 1.3 Note system test

All components of the sceneCOM S system must be DALI-2 certified and listed on the DIIA web-page. sceneCOM S system was tested with Tridonic DALI-2 components only. Check compatibility yourself before installing, if Tridonic DALI-2 components are not used.

## 2.2 Wiring type and cross section

For wiring use stranded wire with ferrules or solid wire from 0.2 to 1.5 mm<sup>2</sup>. Maximum cable length between momentary switch and sceneCOM S is 50 cm.

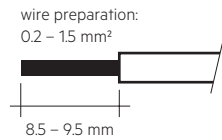

## 2.3 Terminals

Orange = DALI D1 and D2  
Grey = Push button inputs T1 – T4  
Purple = Push button common

## 2.4 Mounting

Maximum range of the signal is up to 20 m.  
Avoid mount the device behind glass or concrete surfaces and in metal enclosures.  
If mounted behind such materials the signal range will be reduced.

## 2.5 Configuration

For commissioning and configuration the App „sCS commissioning“ (sceneCOM S) is provided by Tridonic. App can be installed on iOS and Android devices. Compatible with Android 6.0 / iOS 10 or later. Recommended to be used with devices with a min. screen size of 20 cm diagonal and a min. resolution of 1,024 x 768 pixels. The device must support Bluetooth Low Energy version 4.1 or higher.

Android:



iOS:



## 2.6 Application Controller Features

The Application Controller is developed to be future safe. To achieve this the firmware can be updated via the commissioning app over the air. Features like addressing, grouping, scenes are already implemented and can be used.

- Number of control gears = 64
- TuWh, Device Type 8 (as specified in IEC-62386-209 Ed.1) fully supported
- Number of input devices in total = 16
- Max. 224 instances in total supported
- Number of groups = 16 according to DALI-2 Standard
- Number of scenes = 16 according to DALI-2 Standard

All Tridonic DALI-2 control devices e. g. MSensor G3 or DALI XC G3 are fully implemented and configurable.

As the application controller supports an easy way to update the firmware and develop new features an additional document with the extended release notes is available and can be downloaded from the Tridonic web page.

**2.7 Placement**

Device has an integrated antenna. Certain materials can reduce the range of the antenna. During assembly, the following should be observed.

The antenna is located at the corner of the case, at the bottom of the PCB, just above the bottom of the device. By placing the antenna at this point, the influence of other components on the antenna performance is minimized. In addition, the device should be placed as far away as possible from metal structures.

Wires of the device should not lead past the antenna.

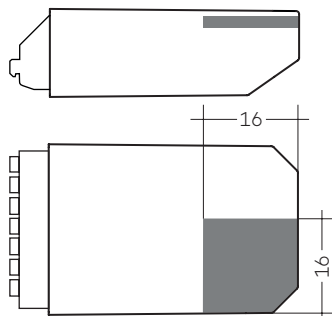

■ Antenna location

**2.8 Status LED**

Device is equipped with an multi color LED placed behind the label.

Depending on colour and flashing pattern different status information are provided.

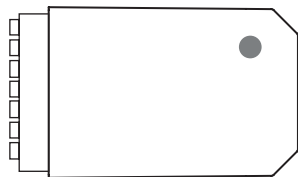

Status LED	Indicates
Blue blinking	Bluetooth connection active
Red blinking	At least one input closed

**3. Miscellaneous**

**3.1 Disposal of equipment**



Return old devices in accordance with the WEEE directive to suitable recycling facilities.

**3.2 Additional information**

Additional technical information at [www.tridonic.com](http://www.tridonic.com) → Technical Data

Guarantee conditions at [www.tridonic.com](http://www.tridonic.com) → Services

Lifetime declarations are informative and represent no warranty claim. No warranty if device was opened.